

A high-performance cryogenic amplifier based on a radio-frequency single electron transistor

K. Segall,^{a)} K. W. Lehnert, T. R. Stevenson,^{b)} and R. J. Schoelkopf
Department of Applied Physics, Yale University, New Haven, Connecticut 06520

P. Wahlgren, A. Aassime, and P. Delsing
Department of Microelectronics and Nanoscience, Chalmers University of Technology and Goteborg University, S-412 96 Goteborg, Sweden

(Received 23 May 2002; accepted 24 October 2002)

We demonstrate a high-performance cryogenic amplifier based on a radio-frequency single-electron-transistor (rf-SET). The high charge sensitivity and large bandwidth of the rf-SET, along with low power dissipation, low capacitance and on-chip integrability, make it a good candidate for a general-purpose cryogenic amplifier for high impedance sources. We measure a large-gate rf-SET with an open-loop voltage noise of $30 \text{ nV}/\sqrt{\text{Hz}}$, among the lowest reported voltage noise figures for a SET. Using a closed-loop transimpedance configuration, the amplifier shows almost 2 orders of magnitude increase in dynamic range, a 3 dB bandwidth of 30 kHz, and a transimpedance gain of $50 \text{ V}/\mu\text{A}$ for a cryogenic $1 \text{ M}\Omega$ load resistor. The performance of this amplifier is already sufficient for use as an integrated readout with some types of high-performance cryogenic detectors for astrophysics. © 2002 American Institute of Physics. [DOI: 10.1063/1.1530751]

The use of the single electron transistor (SET),¹ which can in principle² form a near-quantum limited amplifier, has received attention over the past decade due to its high charge sensitivity. This charge sensitivity has already been utilized in experiments in mesoscopic physics and single electron metrology,³ but its use as a more general-purpose cryogenic amplifier has yet to be explored. One of the previous difficulties of the SET was the inability to realize its full signal bandwidth, a problem that has been improved by the introduction of the radio-frequency single-electron transistor (rf-SET).⁴ With the rf-SET, bandwidths greater than 100 MHz have been obtained, making it a more attractive general-purpose amplifier. SETs have historically presented two other problems for making a practical amplifier. The first is that most SETs have extremely small input (gate) capacitances ($\sim 10^{-17} \text{ F}$), which result in high voltage noise despite the low charge noise. The second is that the nonlinear, periodic transfer function of the SET results in poor dynamic range.

Nevertheless, SET amplifiers offer many potential benefits as a readout for high-performance cryogenic detectors.⁵ For example, in comparison to conventional Si J-FET amplifiers, the SET can operate at 10^{10} times lower power dissipation, 10^3 times lower temperature, and 10^4 times smaller input capacitance. Therefore, they can be integrated directly with sub-Kelvin detectors, simplifying multichannel applications, and allowing larger readout bandwidths. The SET amplifier shares these advantages with the superconducting quantum interference device (SQUID), which has already been successful as a readout for low impedance cryogenic

detectors,⁶ and has some of the lowest reported noise temperatures.⁷ While the SQUID is ideal for low impedance sources,⁸ the SET, which is the electromagnetic dual of the SQUID, performs best for high impedance sources.

In this letter we present a demonstration of a high-performance amplifier based on a rf-SET. A large input gate capacitance of 0.5 fF is used to give an open-loop, input voltage noise of $30 \text{ nV}/\sqrt{\text{Hz}}$, among the lowest reported voltage noise figures for a SET.^{9,10} We configure the rf-SET in a closed loop, transimpedance configuration, which increases its dynamic range by almost two orders of magnitude. We demonstrate that we can measure the current through a cryogenic $1 \text{ M}\Omega$ load resistor with a transimpedance gain of $50 \text{ V}/\mu\text{A}$ and a 3 dB bandwidth of 30 kHz. We discuss the amplifier demonstration, we quantify gain and noise performance, and we present projections of future amplifier performance.

A schematic of the amplifier is shown in Fig. 1(a). The amplifier input is the gate of a SET, formed by an interdigitated capacitor [Fig. 1(b)] which has an input capacitance to the central island of 0.5 fF. Two aluminum tunnel junctions [drawn as boxes with horizontal lines in Fig. 1(a)] connect the island to the source and drain leads. A smaller trim gate ($C_{\text{trim}}=10 \text{ aF}$) is also capacitively coupled to the island. A resonant tank circuit surrounds the SET and allows for the rf readout. The SET is mounted on a rf circuit board in series with a surface mount inductor of $L_T=240 \text{ nH}$. The inductor's mounting pad has a parallel capacitance to ground of $C_T=0.45 \text{ pF}$. The resulting tank circuit has a resonant frequency of $f_{\text{res}}=1/(2\pi)/(L_T C_T)^{1/2}=485 \text{ MHz}$. Also mounted on the circuit board are load (R_L), input (R_{in}) and feedback (R_F) resistors, with $R_L=R_{\text{in}}=R_F=1 \text{ M}\Omega$. The circuit board is mounted in a copper light-tight box and cooled to 250 mK. High frequency coax connections are made to the tank circuit, and the input and feedback resistors. A directional coupler is used to apply rf carrier power to the tank circuit while

^{a)}Present address: Department of Electrical Engineering and Computer Science, Massachusetts Institute of Technology, Cambridge, MA 02139; electronic mail: ksegall@mit.edu

^{b)}Present address: Detector Systems Branch, NASA Goddard Space Flight Center Code 553, Greenbelt, MD 20771.

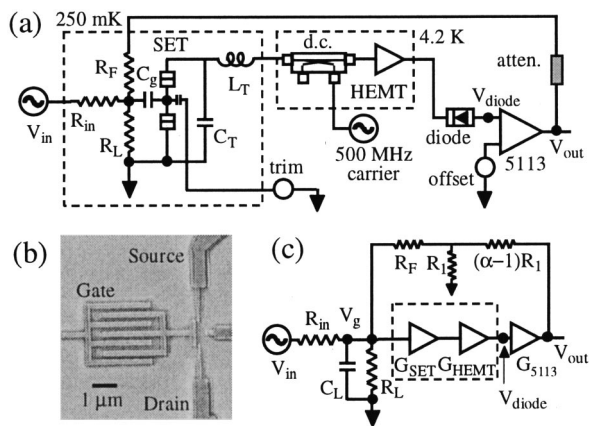

FIG. 1. (a) Amplifier configuration, showing the rf readout and feedback; (b) SEM of the SET, showing the large gate capacitor with interdigitated fingers; (c) amplifier schematic showing the rf-SET voltage amplifier (dashed box).

monitoring the reflected power with a cryogenic high electron mobility transistor (HEMT) amplifier. The directional coupler and the HEMT amplifier are both mounted in the 4.2 K bath. In operation the HEMT amplifier dissipates 10–100 mW of power into the helium bath.

The HEMT amplifier's signal is rectified by a diode located at room temperature, which gives a negative output voltage proportional to the power reflected from the tank circuit. The difference between the diode's voltage and an adjustable offset is amplified by an audio amplifier (the EG&G 5113). Its output is attenuated by a factor of $\alpha=50$ and then fed back through the feedback resistor to the input gate. A bias tee (not shown) is connected to the source-drain lead to allow a dc bias voltage to be applied to the SET in conjunction with the rf.

In closed loop operation, an increase in the voltage at the gate causes a decrease in the source-drain conductance of the SET, causing an increase in the power reflected from the tank circuit⁴ and thus a decrease in the voltage at the diode. This decrease in output voltage in turn causes a decrease in the current through the feedback resistor and thus in the gate voltage, which tends to counteract the original increase and makes the feedback stable.

We performed measurements of the gain and noise to demonstrate the operation of the rf-SET amplifier. First we measured the small-signal gain and noise in the open-loop configuration, without the connection from the 5113 output to the feedback resistor, and then measurements were repeated closed loop, with the feedback resistor connected. We also measured the response to a large-signal input, both open and closed loop, to test the dynamic range.

First we discuss the properties of the rf-SET voltage amplifier, which we define as the stages from the gate of the SET (V_g) to the output of the diode (V_{diode}). In Fig. 1(c) we redraw Fig. 1(a) as a more simplified schematic and indicate the rf-SET voltage amplifier by the dashed box. It is formed by the SET, the HEMT amplifier, and the diode. It functions as a voltage amplifier of modest gain ($V_{\text{diode}}/V_g \sim 5$), low noise and very large bandwidth. The 5113 acts as a second stage amplifier to add additional gain and to condition the response for stable feedback.

The large-signal response of the rf-SET voltage amplifier

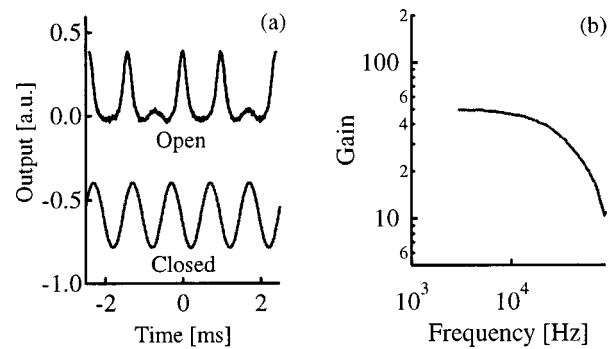

FIG. 2. (a) Response to large sinusoidal signal open loop (one electron peak-to-peak magnitude) and closed loop (12 electrons peak-to-peak). The SET gain changes over the course of an input cycle in the open-loop case and results in the complicated shape. In the closed-loop case the feedback keeps the gain fixed and restores the signal; (b) small signal closed-loop gain vs frequency, with a 3 dB rolloff at 30 kHz.

is indicated in Fig. 2(a). The dc bias of the SET was adjusted to be on the Josephson–quasiparticle (JQP)¹¹ resonance, which was generally found to have the greatest sensitivity for large-gate superconducting SETs. The transfer function is periodic in input voltage, with each period corresponding to the addition of one electron on the gate, but with a complicated shape due to the details of the JQP resonance. The open-loop dynamic range is limited by the periodic transfer function to voltages $V_{\text{in}} \sim 0.1(e/C_g)$, where $e = 1.6 \times 10^{-19}$ C, but can be greatly enhanced by the closed-loop operation (see below).

The rf-SET has already demonstrated bandwidths in excess of 100 MHz. The bandwidth of this rf-SET voltage amplifier is limited by the resonance of the tank circuit to about 50 MHz. In closed loop operation the achievable bandwidth is limited by stability considerations on the feedback (see below).

The noise for the rf-SET amplifier is shown in Fig. 3. The noise at higher frequencies is $v_n = 30 \text{ nV}/\sqrt{\text{Hz}}$ and has a $1/f$ knee of around 3 kHz, due to background charge fluctuations. The noise of a SET is often quantified in terms of charge noise q_n , where $q_n = C_g v_n$. The measured voltage noise, v_n , then corresponds to a charge noise of $1 \times 10^{-4} e/\sqrt{\text{Hz}}$. It is possible that $30 \text{ nV}/\sqrt{\text{Hz}}$ is not yet the optimum for a SET device, given that SETs with much smaller gate capacitances have demonstrated charge noises of order $10^{-6} e/\sqrt{\text{Hz}}$,¹⁰ although the tradeoff between charge noise and gate capacitance has yet to be determined. Even this level of voltage noise is impressive given the SETs

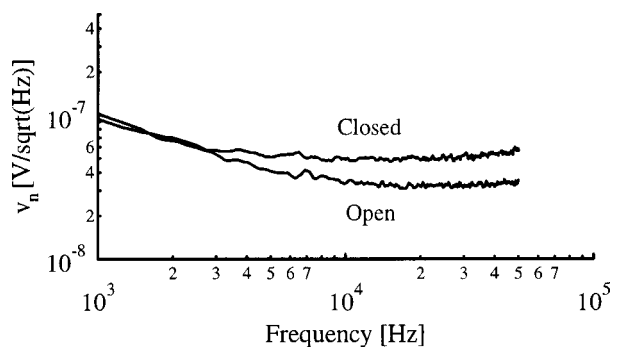

FIG. 3. Open- and closed-loop noise vs frequency. The open-loop noise is about $30 \text{ nV}/\sqrt{\text{Hz}}$ at high frequency (>10 kHz). The closed-loop noise is about a factor of two higher due to a shift in the operating point of the SET.

low expected current noise and large input impedance.² A typical FET amplifier will have lower voltage noise but higher current noise, so the rf-SET may be the better choice at higher impedances.

In order to close the feedback loop one must satisfy the usual amplifier stability criteria.¹² The parasitic capacitance of the load resistor provides the important phase shift at $\omega_{in}=1/R_L C_L=80$ kHz. This parasitic capacitance was largely due to the metal film resistor used for R_L . The value of C_L can be made much smaller in future devices. For stable operation, the 5113 was adjusted to have a gain of 5000 at dc but intentionally filtered with a 300 Hz, single-pole low-pass filter in order to keep the unity gain point of the loop below 80 kHz. The loop was not stable with a higher rolloff frequency.

We demonstrate the closed-loop operation by observing the response for a large (12 electrons peak-to-peak) signal, also shown in Fig. 2(a). The original sinusoidal signal is now recovered, as the feedback keeps the operating point and thus the gain of the SET fixed. This 12 electron signal was the largest for which the loop stayed locked and corresponds to an increase in the dynamic range by about two orders of magnitude. The signal in Fig. 2(a) could be applied for periods of 1 h without unlocking, showing robustness against background charge fluctuations. The closed-loop gain for small signals (V_{out}/V_{in}), shown in Fig. 2(b), has a constant value of 50 up to about 30 kHz. This is perhaps the highest bandwidth obtained for the readout of a cryogenic 1 M Ω load. The input voltage (V_{in}) and the input resistance (R_{in}) can alternatively be thought of as an input *current*, in which case the amplifier behaves as a *transimpedance* amplifier.¹² The transimpedance gain is 50 V/ μ A below 30 kHz. The closed loop gain rolls off because of the drop in gain of the 5113 above 300 Hz, which was again purposely introduced to maintain stability. With a smaller load capacitance this rolloff can be chosen to be larger. A load capacitance of 0.1 pF should be attainable with an integrated, on-chip feedback resistor and would allow bandwidths of order 1 MHz at a load resistance of 1 M Ω .

The closed-loop noise is also shown in Fig. 3. At low frequencies the open- and closed-loop noise agree, showing that the noise is dominated by the $1/f$ input voltage noise of the SET. At higher frequencies, the noise of the rf-SET voltage amplifier is dominated by the noise of the HEMT rf readout. In closed-loop operation, the SET spontaneously switches to a point on its transfer function with about a factor of two¹³ smaller gain; this increases the HEMT amplifier's contribution to the total noise at high frequencies by this same factor of two, resulting in the difference between the two curves in Fig. 3. The rf-SET amplifier open-loop output voltage noise as a function of the gain of the SET (not shown) was constant above 3 kHz, confirming that the noise is indeed limited by the HEMT amplifier at these frequencies.

In general, the choice of an amplifier for a particular application depends on many considerations, including the required bandwidth, the operating temperature, and the source impedance. To optimize the signal-to-noise at a given

source impedance, one tries to attain the minimum noise temperature (T_N), expressed as $4kR_L T_N = v_n^2 + i_n^2 R_L^2$, where v_n and i_n are the voltage and current noise, respectively, of the amplifier. For the noise sources of a given amplifier there is an optimum source impedance given by $R_{opt} = v_n / i_n$. For the SET, the optimum impedance² at audio frequencies should be greater than 10 G Ω , meaning the current noise can be neglected for all practical impedance levels. For the 30 nV/ $\sqrt{\text{Hz}}$ voltage noise performance already achieved, and a more optimal source impedance of 100 M Ω , the noise temperature of the rf-SET transimpedance amplifier would be 160 mK, comparable to the best JFET transistors,¹⁴ which have $T_N \sim 50$ mK. This noise is suitable for several types of cryogenic detectors which have output impedances of order 100 M Ω , such as x-ray calorimeters, infrared bolometers, and superconducting direct-detectors (SQPC)¹⁵ for submillimeter waves. For example, in an SQPC¹⁵ with 100 M Ω dynamic resistance and 1 pA dark current, the SET readout noise is negligible compared to the shot noise. While an alternative readout using cooled FETs can produce comparable noise performance, the small capacitance of the SET gives larger bandwidths. The further advantages of easier integration, smaller size, power dissipation, and the use of multiplexed rf-SET readouts¹⁶ also make the SET appealing for array applications.

The authors thank D. E. Prober, A. E. Szymkowiak, and S. H. Moseley for useful discussions. The devices were fabricated in the Swedish Nanometer Laboratory. This work was supported by the Wallenberg Foundation, the EU under the IST-SQUBIT program, by NASA JPL Code S and NASA NSG-8589.

¹T. A. Fulton and G. J. Dolan, Phys. Rev. Lett. **59**, 109 (1987).

²M. H. Devoret and R. J. Schoelkopf, Nature (London) **406**, 19 (2000).

³M. H. Devoret and H. Grabert, *Single Charge Tunneling* (Plenum, New York, 1992); M. W. Keller, A. L. Eichenberger, J. M. Martinis, and N. M. Zimmerman, Science **285**, 1706 (1999).

⁴R. J. Schoelkopf, P. Wahlgren, A. A. Kozhevnikov, P. Delsing, and D. E. Prober, Science **280**, 1238 (1998).

⁵J. Mather, Nature (London) **401**, 654 (1999); N. Booth and D. Goldie, Supercond. Sci. Technol. **9**, 493 (1996).

⁶K. D. Irwin, G. C. Hilton, D. A. Wollman, and J. M. Martinis, Appl. Phys. Lett. **69**, 1945 (1996); J. A. Chervanek, K. D. Irwin, E. N. Grossman, J. M. Martinis, C. D. Reintsema, and M. E. Huber, *ibid.* **74**, 4043 (1999).

⁷M.-O. Andre, M. Muck, and J. Clarke, Appl. Phys. Lett. **75**, 698 (1999).

⁸K. K. Likharev, IEEE Trans. Magn. **MAG-23**, 1142 (1987).

⁹G. Zimmerli, R. L. Kautz, and J. M. Martinis, Appl. Phys. Lett. **61**, 2616 (1992).

¹⁰A. Aassime, D. Gunnarsson, K. Bladh, P. Delsing, and R. J. Schoelkopf, Appl. Phys. Lett. **79**, 4031 (2001).

¹¹T. A. Fulton, P. L. Gammel, D. J. Bishop, and L. N. Dunkleberger, Phys. Rev. Lett. **63**, 1307 (1989).

¹²J. Graeme, *Photodiode Amplifiers* (McGraw-Hill, New York, 1995).

¹³With the parasitic phase shifts present in our apparatus a stable operating point at maximum SET gain was not possible. Reduction of these parasitics along with a reduction of the load capacitance should allow an optimal setting of the gain.

¹⁴2SK 147 JFET has an optimum impedance of 1.2 M Ω , a noise temperature of 30 mK, and an input capacitance of 150 pF; see P. L. Richards, J. Appl. Phys. **76**, 1 (1994).

¹⁵R. J. Schoelkopf, S. H. Moseley, C. M. Stahle, P. Wahlgren, and P. Delsing, IEEE Trans. Appl. Supercond. **9**, 2935 (1999).

¹⁶T. R. Stevenson, F. A. Pellerano, C. M. Stahle, K. Aidala, and R. J. Schoelkopf, Appl. Phys. Lett. **80**, 3012 (2002).